



WHITACRE GREER
 1400 S. MAHONING AVE.
 ALLIANCE, OH 44601
 TOLL FREE: 1-800-947-2837
 PHONE: (330) 823-1610
 FAX: (330) 823-5502
 www.wgpaver.com

SELECT DESIRED SIZE:
 (WIDTH X LENGTH X HEIGHT)

2 1/4 X 9 X 2 1/4

3 X 9 X 3

2 1/4 X 9 X 3

3 X 9 X 2 1/4 (FACE TEXTURE NOT CONSISTENT WITH
 OTHER BOARDWALK PAVERS - REQUEST SAMPLE)

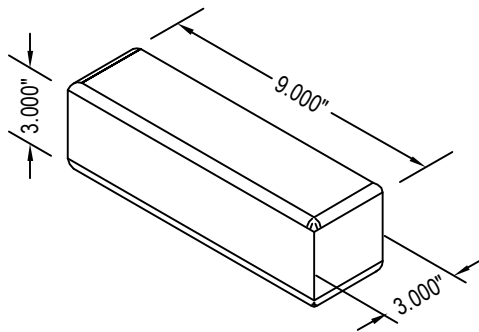

PERSPECTIVE

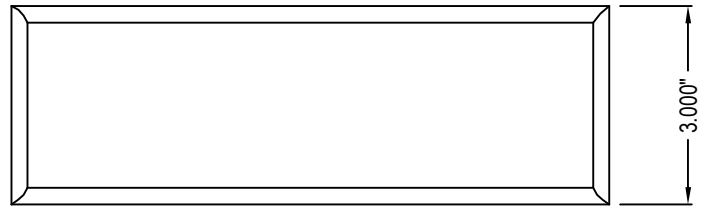

PLAN VIEW

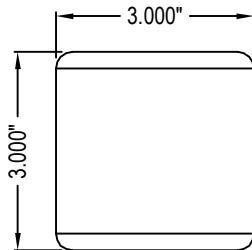

SIDE ELEVATION

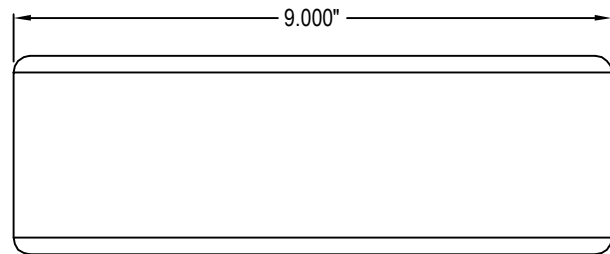

FRONT ELEVATION

NOTES:

1. COMPLIES WITH ASTM C902 CLASS SX TYPE I APPLICATION PS. APPLICATION PX AVAILABLE ON REQUEST. ASTM C1272 TYPE R AVAILABLE ON REQUEST
2. AVAILABLE IN ALL STANDARD COLORS. STANDARD COLORS MAY BE MINGLED AT THE PLANT PER ARCHITECT'S SPECIFICATION.
3. INSTALLATION TO BE COMPLETED IN ACCORDANCE WITH MANUFACTURER'S SPECIFICATIONS.
4. DO NOT SCALE DRAWING.
5. THIS DRAWING IS INTENDED FOR USE BY ARCHITECTS, ENGINEERS, CONTRACTORS, CONSULTANTS AND DESIGN PROFESSIONALS FOR PLANNING PURPOSES ONLY. THIS DRAWING MAY NOT BE USED FOR CONSTRUCTION.
6. ALL INFORMATION CONTAINED HEREIN WAS CURRENT AT THE TIME OF DEVELOPMENT BUT MUST BE REVIEWED AND APPROVED BY THE PRODUCT MANUFACTURER TO BE CONSIDERED ACCURATE.
7. CONTRACTOR'S NOTE: FOR PRODUCT AND COMPANY INFORMATION VISIT WWW.CADDETAILS.COM/INFO AND ENTER REFERENCE NUMBER 256-124.

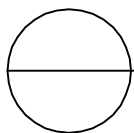

PAVERS

BOARDWALK WITHOUT LUGS